

## DESCRIPTION

The F-2000 Series Speaker are compact two-way speaker systems designed for high efficiency, wide range, and high power input handling capability. These speaker systems can be installed in a manner ideal for the location and intended application.

## SPECIFICATIONS

Enclosure	Bass-reflex type
Rated Input	60 W
Rated Impedance	100 V line: 170 Ω (60 W), 330 Ω (30 W), 670 Ω (15 W), 3.3 kΩ (3 W) 70 V line: 83 Ω (60 W), 170 Ω (30 W), 330 Ω (15 W), 670 Ω (7.5 W), 3.3 kΩ (1.5 W)
Sensitivity	92 dB (1 W, 1 m) at installation in 1/2 free sound field 93 dB (1 W, 1 m) at installation in 1/2 free sound field (with horn adapter)
Frequency Response	65 - 20,000 Hz, -10 dB at installation in 1/2 free sound field
Crossover Frequency	2.5 kHz
Directivity Angle	Horizontal: 110°, Vertical: 100° Horizontal: 80°, Vertical: 80° (with horn adapter)
Speaker Component	Low frequency: 20 cm (8") cone-type High frequency: 25 mm (1") dome tweeter
Input Terminal	Push-in terminal
Finish	Enclosure: HIPS, black Punched net: Surface-treated steel plate, black, paint Joint bracket, wall bracket: Steel plate, t2.0, black, paint Speaker bracket: Die-cast aluminum, black, paint
Dimensions	244 (W) × 373 (H) × 235 (D) mm (9.61" × 14.69" × 9.25")
Weight	7.4 kg (16.31 lb) (including the supplied brackets)
Accessory	Speaker bracket ...1, Joint bracket ...1, Wall bracket ...1, Bracket fixing screw ... 1 set, Horn adapter ...1, Horn adapter mounting screw ...4
Option	Ceiling mount bracket: HY-CM20B (used for the horizontal speaker mounting) Cluster bracket: HY-CL20B Speaker stand: ST-16A

Note: Bolts and nuts for mounting the bracket to the wall or ceiling are not included. Prepare them separately.

## APPEARANCE

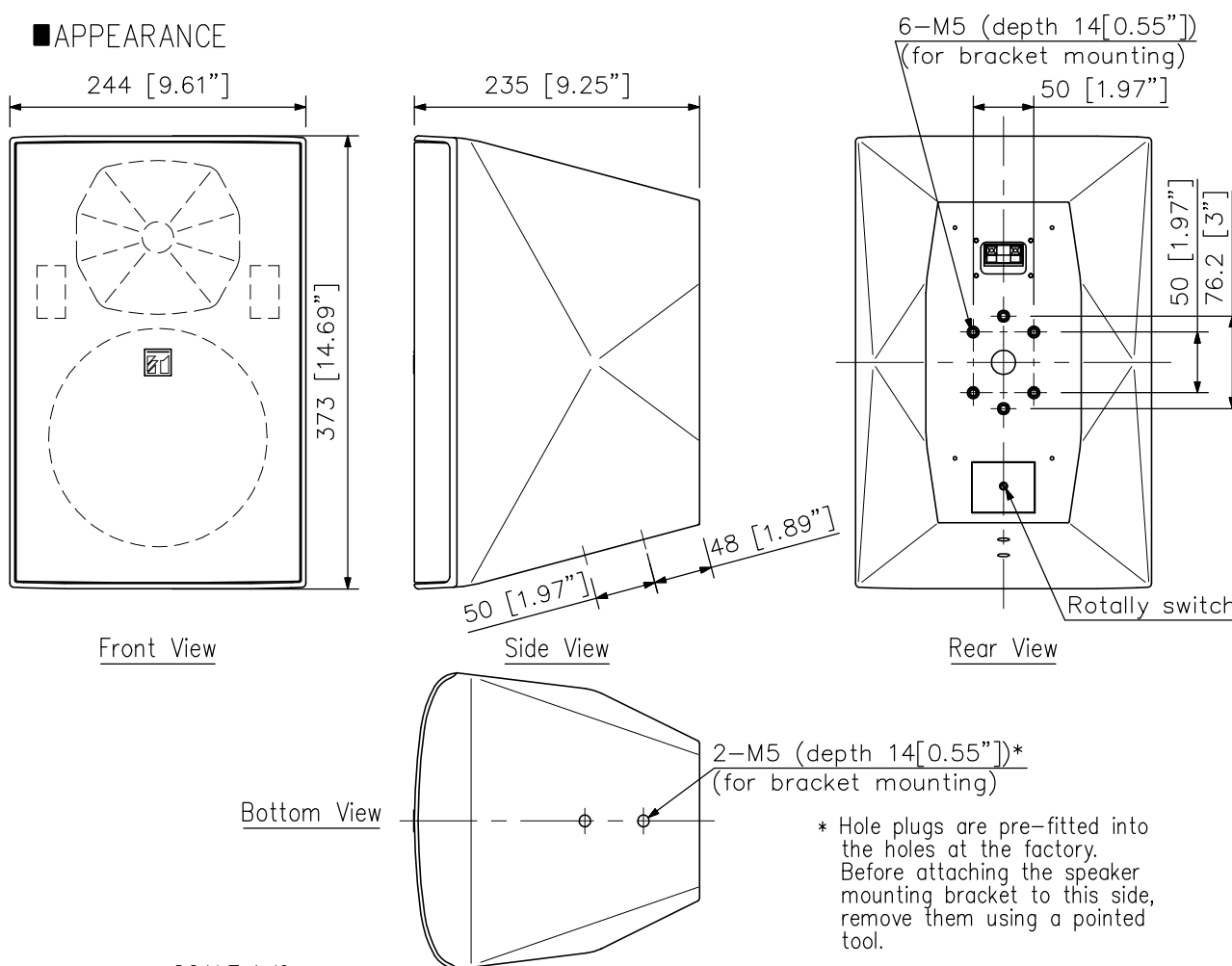

UNIT:mm SCALE:1/6

**■ APPEARANCE**

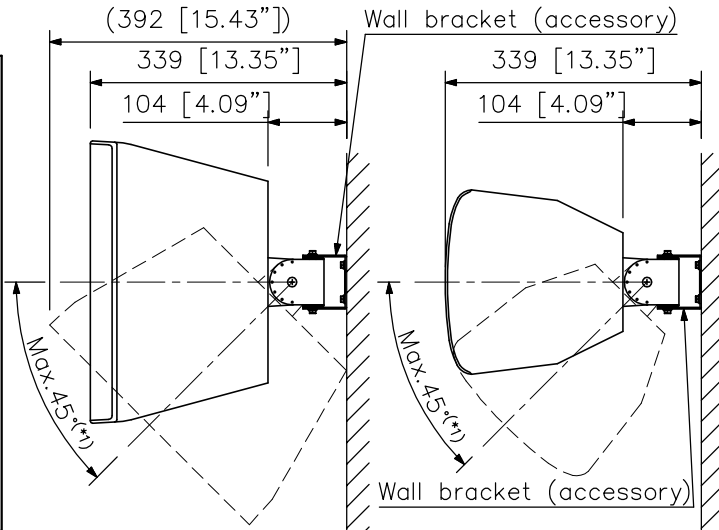
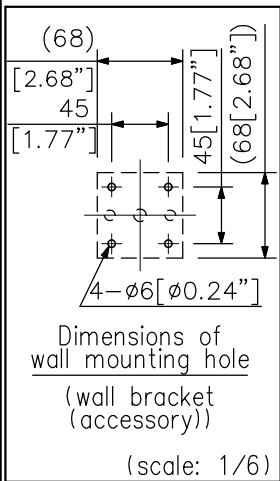

(\*1) The speaker vertical angle adjustable in 7.5° steps.

(\*2) Adjustable angle (vertical speaker mounting)

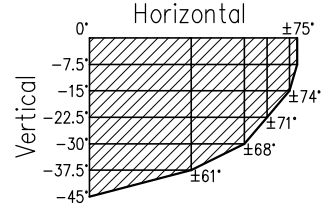

(\*3) Adjustable angle (horizontal speaker mounting)

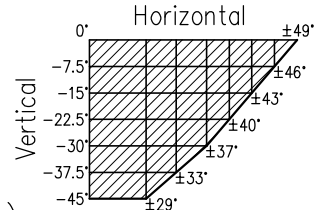

Up to 75° left or right is adjustable in a horizontal direction. (\*2)

Up to 49° left or right is adjustable in a horizontal direction. (\*3)

**Wall mounting example**

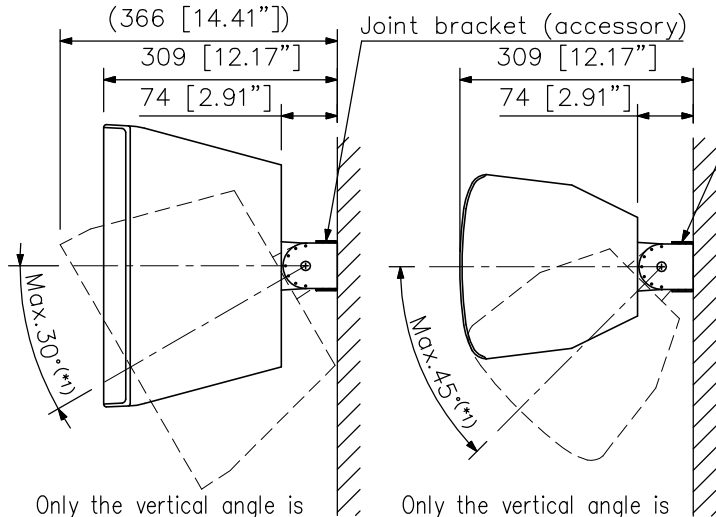
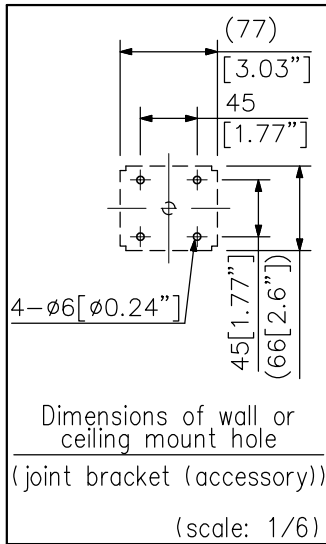

Only the vertical angle is adjustable.

Only the vertical angle is adjustable.

**Mounting the speaker close to a wall surface**

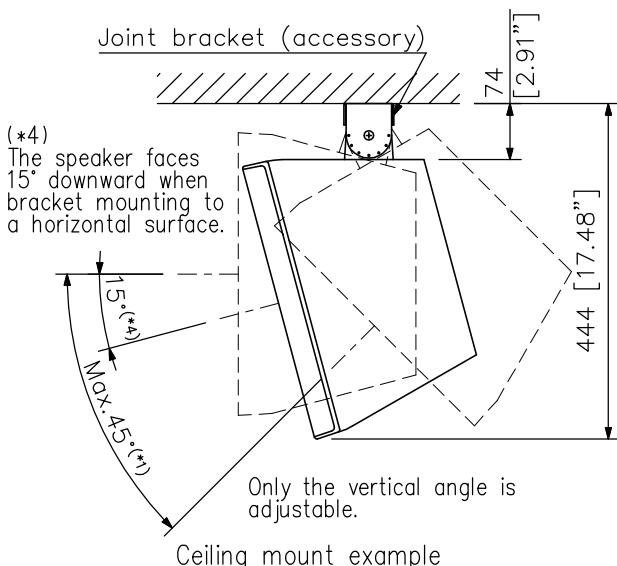

**Ceiling mount example**  
(Only the vertical speaker mounting is allowed.)

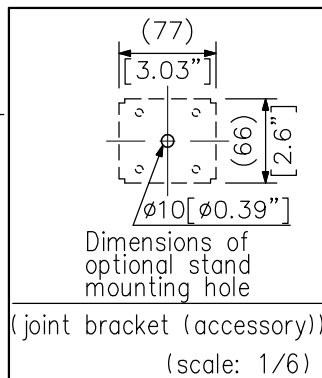

ST-16A (option)

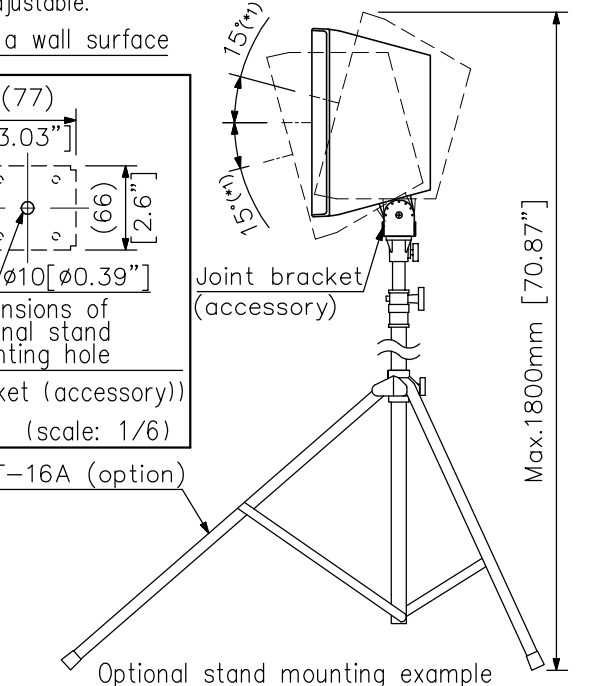

UNIT: mm SCALE: 1/10

(Only the vertical speaker mounting is allowed.) (scale: 1/15)