



DNH^{AS}

**N-3770 Kragerø
NORWAY**
 Phone: (47) 35 98 56 00
 Fax: (47) 35 98 56 10
 E-mail: dnh@dnh.no
 Web-site: www.dnh.no

**DNH WW Ltd.
England** Phone:.....(44) 1908 275 000
 Fax:.....(44) 1908 275 100
 E-mail:.....dnh@dnh.co.uk

**DNH
France** Phone:.....(33) 1 5380 0276
 Fax:.....(33) 1 4588 1594
 E-mail:.....etienne@dnh.no

**DNH GmbH
Germany** Phone:.....(49) 040 6569 30-0
 Fax:.....(49) 040 6569 30-30
 E-mail:.....dnh@dnh.de

**DNH
Speakers Inc.
USA** Phone:.....(1) 484 494 5790
 Fax:.....(1) 484 494 5793
 E-mail:.....dnh@dnhspeakers.com

DST-100

ISO 9001 CERTIFIED

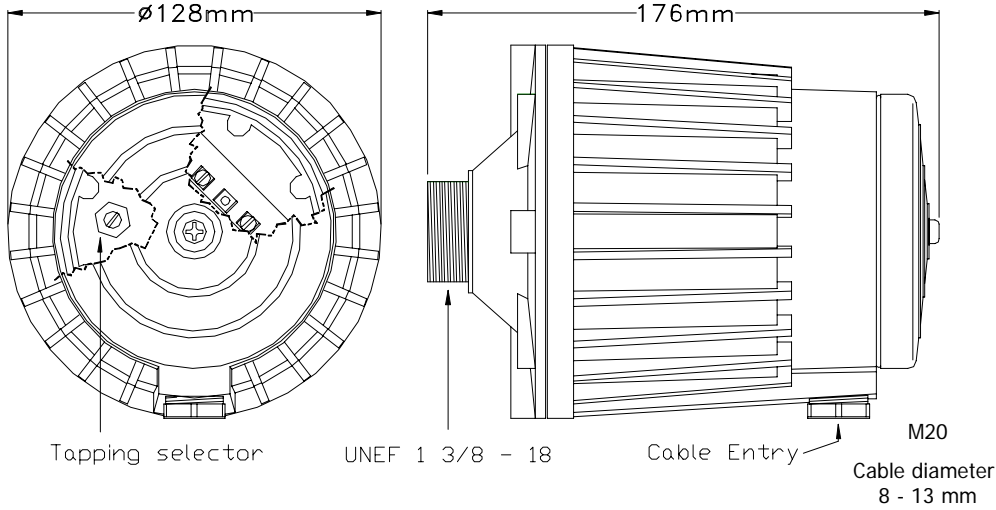

100 Volt line

Secondary switch
tappings:

1/1	100,0 W
1/2	60,0 W
1/4	30,0 W
1/8	15,0 W
1/16	7,5 W

100W/1m Pink Noise 1/3 octave bands

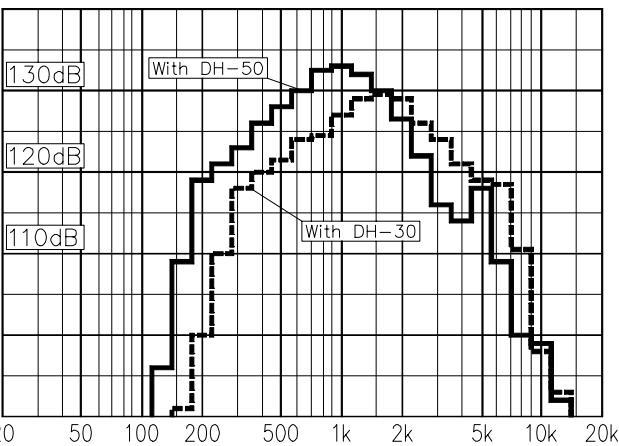

DH-50 DH-30

Material / Color Aluminum alloy / RAL 7035
 Mounting Threaded UNEF 1 3/8 - 18
 Termination Inside screw terminals
 Weight driver unit 2,5 kg
 IP-rating (UL equivalent) 67
 Max / min amb temp 200 °C / -50 °C
 Rated / max power 100 W / 100 W
 SPL 1W/1m with horn 112 dB 110 dB
 SPL rated power with horn 132 dB 130 dB
 Effective freq range with horn 200 - 5000 Hz 300-5000
 Dispersion (-6dB) 1kHz / 4kHz 50° / 20° 80° / 25°
 Options Impedances, colors, labels

Installation, Operation and Maintenance Procedures

- Screw driver unit into a suitable horn (ie. DNH modell DH-30).
- For optimum performance, always use the correct voltage / power and operate within the frequency limits as stated.
- The loudspeaker should be checked on a regular basis to avoid any build up of debris.
- This loudspeaker is supplied with a 2 year warranty against defective materials and workmanship.



DNH reserves the right to alter specifications without notice.

Rev. 12.02.2007